

- 1) Oil Conservator
- 2) Magnetic Oil level indicator(without contact)
- 3) Dehydrating breather
- 4) HV Bushing 33/250-900
- 5) LV Bushing DT1/250 (DIN 42530)
- 6) Off circuit tap changer
- 7) Lifting lugs for complete transformer and active part
- 8) Terminal sheet
- 9) Rating plate
- 10) Oil drain and down sampling device (DIN 42551)
- 11) Earthing screw M12
- 12) Pulling lug $\phi 30$
- 13) Filling cap for conservator
- 14) Drain for conservator

Weights

Untanking :	317 kg
Oil :	166 kg
Total :	580 kg

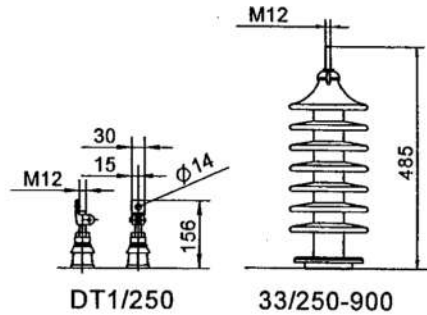

Rating Power: 50 kVA
 Voltage Ratio: 33/ 0.4 kV
 Tender: Low Losses - AB'

Comment: Paint: RAL 7032

* Dimensions and weights are approx.

Design: *AZ*

95.6.14

Control: *SL*

95.6.14

Approval: *SL*

95.6.14