

- 1) Oil Conservator
- 2) Magnetic Oil level indicator(without contact)
- 3) Dehydrating breather
- 4) HV Bushing 33/250-900
- 5) LV Bushing DT1/630 (DIN 42530)
- 6) Off circuit tap changer
- 7) Lifting lugs for complete trans and active part
- 8) Terminal sheet
- 9) Rating plate
- 10) Oil drain and down sampling device (DIN 42551)
- 11) Earthing screw M12
- 12) Pulling lug $\phi 30$
- 13) Filling cap
- 14) Drain for conservator
- 15) Oil thermometer pocket-R1"

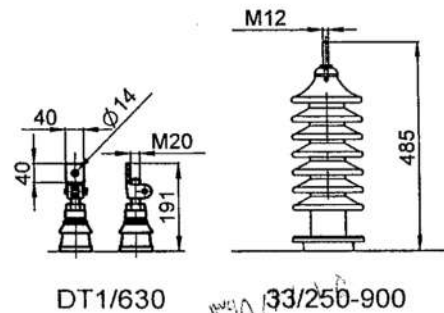
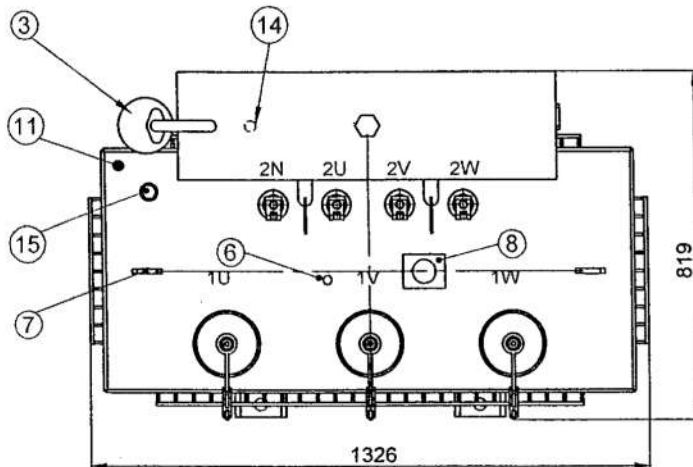

Weights

Untanking :	750 kg
Oil :	335 kg
Total :	1225 kg

Rating Power:	200 kVA
Voltage Ratio:	33 / 0.4 kV
Tender:	Low Loss-AB'

Comment: Paint: RAL 7032

* Dimensions and weights are approx.

Design: *Aizkhan*

95.6.14

Control: *[Signature]*

95.6.14

Approval: *[Signature]*

95.6.14